

# AVAILABLE FOR SALE

## 17 BUILDING, 2-STORY 169,278 SF INDUSTRIAL CAMPUS

246 E. 4th Street | Ashland, Ohio



### HIGHLIGHTS



**AVAILABLE SPACE**  
169,278 SF TOTAL



**DOCKS/GARAGE DOORS**  
8 PLUS GARAGE DOORS



**CLEARANCE HEIGHT**  
18 FEET



**CLOSE PROXIMITY**  
TO I-71



**Terry Coyne**  
Vice Chairman  
216.218.0259  
Terry.Coyne@nrmk.com  
Licensed Real Estate Broker



**Claire Coyne**  
Director  
216.453.3015  
Claire.Coyne@nrmk.com  
Licensed Real Estate Salesperson



### OFFICE BUILDING HIGHLIGHTS

- Built in 1930
- 10,000 SF, 2 floors
- Walls non-bearing
- Original brick
- Connects to manufacturing floor
- Safe included
- New roof in 2022
- Freight elevator



### FACILITY HIGHLIGHTS

- 16 interconnected warehouse and factory buildings
- Mega power, 480 amps; substation
- Freight elevators
- Fully sprinklered
- Conveyor belts connect buildings across the street
- Parking: 2 surface lots for 100+ vehicle parking



### LOCATION HIGHLIGHTS

- Rail spur access on site
- Approximately one hour from Cleveland
- Approximately one hour from Columbus
- 10 minutes to I-71

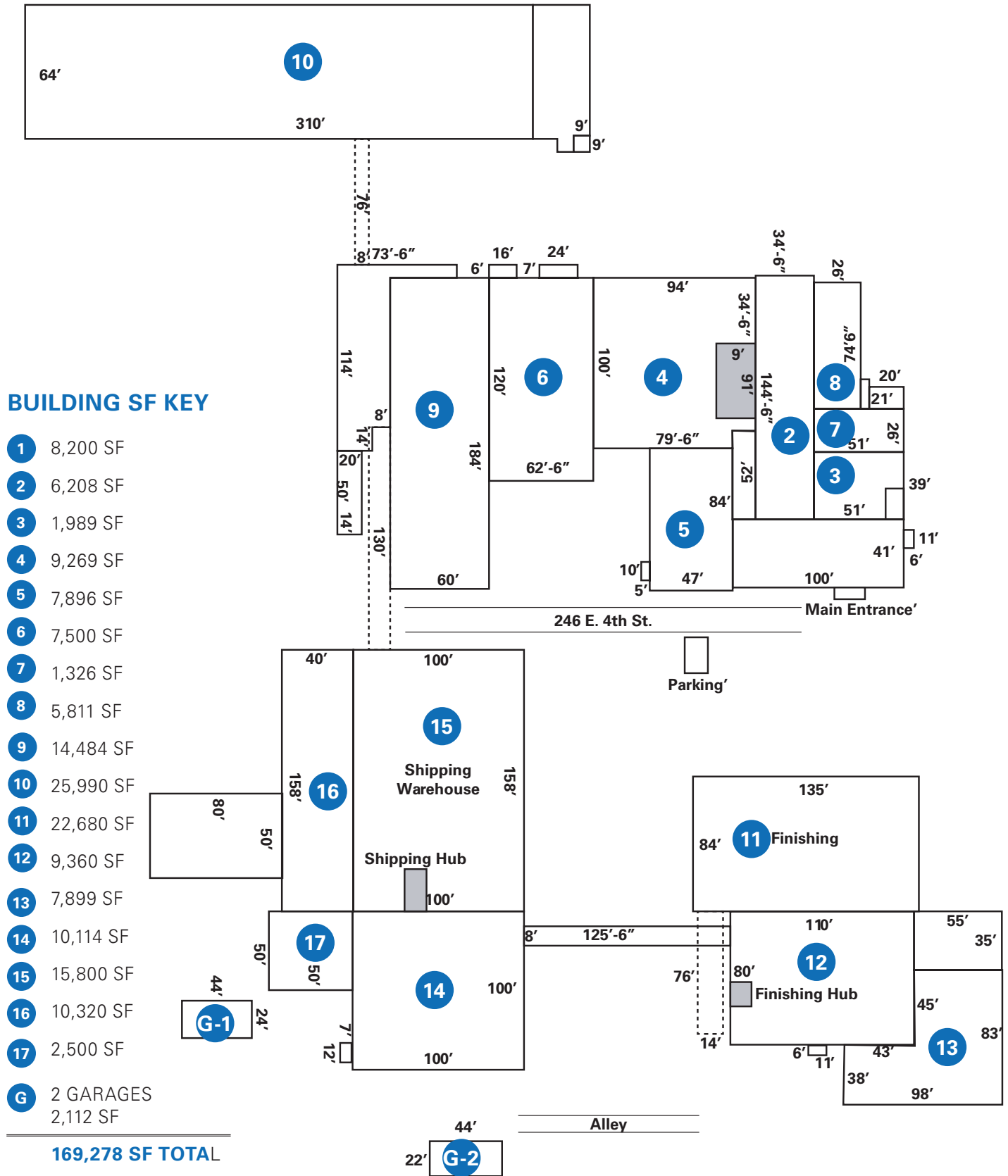





246 E. 4th Street | Ashland, Ohio

## Connector Building Photos



246 E. 4th Street | Ashland, Ohio

Exterior Office Building Photos



























KEY FACTS	EDUCATION	INCOME	EMPLOYMENT	
 <b>122,197</b> Population	 <b>36.8%</b> High School Diploma	 <b>\$52,664</b> Median Household Income	 <b>49.3%</b> White Collar	 <b>17.0%</b> Services
 <b>41.0</b> Median Age	 <b>26.6%</b> Some College	 <b>\$27,995</b> Per Capita Income	 <b>33.7%</b> Blue Collar	 <b>4.6%</b> Unemployment Rate
 <b>47,560</b> Households	 <b>17.8%</b> Bachelors/ Graduate/ Professional Degree	COMMUTERS	BUSINESS	
 <b>\$44,764</b> Median Disposable Income		 <b>12.3%</b> Spend 7+ hours commuting to and from work per week	 <b>32,594</b> Total Businesses	 <b>512,259</b> Total Employees



LOCATION	DRIVE TIME	DRIVING DISTANCE
Akron, Ohio	48 minutes	48 miles
Cleveland, Ohio	1 hour and 3 minutes	65 miles
Columbus, Ohio	1 hour and 16 minutes	80 miles
Toledo, Ohio	1 hour and 45 minutes	99 miles
Pittsburgh, Pennsylvania	2 hours and 33 minutes	156 miles
Detroit, Michigan	2 hours and 34 minutes	153 miles
Cincinnati, Ohio	2 hours and 51 minutes	187 miles
Indianapolis, Indiana	3 hours and 49 minutes	253 miles
Buffalo, New York	3 hours and 57 minutes	250 miles
Chicago, Illinois	5 hours and 18 minutes	330 miles
Toronto, Canada	5 hours and 41 minutes	351 miles

